



DATE	
PROJECT	
TYPE	
NOTE	
PREPARED BY	

**SL-CLP-TC**

**LED Pole Mount Fixture**



The **SL-CLP-TC** has an elegant design that adds style and class to any location. A few locations that this fixture is suitable for are: townships, parks, walkways, housing communities, and driveways. Internally, the **SL-CLP-TC** is durable, reliable and designed to tolerate wet locations. A 10 year/100,000 hour limited warranty is included along with your investment.

**FEATURES**

- Energy Savings: Over 60% compared to HID light sources
- Improved lumen maintenance
- Manufactured with high efficient Lumiled® LED'S
- Operating Temperatures: -30°C ~ 60°C
- Driver: Constant current, 120-277v, 50/60Hz, 480v (Optional)
- Suitable for wet locations
- Operating life: >200,000 hours

**CONSTRUCTION**

- Housing is heavy-duty die-cast aluminum
- Powder coat bronze finish (standard) various colors available (custom/add'l cost)
- Clear glass lens (standard), frosted acrylic lens (optional)
- Silicone gasket to prevent leakage and provide weather-tight protection
- Mounting: Mounting: Comes ready to mount on top of a 3" round pole (standard), 4" round pole (optional)

**OPTIONS**

- (PC) Button Photo Cell
- (HSS) House Side Shield
- (WC) Wireless Controls
- (MG) Marine Grade Finish



MODEL #	INPUT POWER	LUMEN OUTPUT	SCOTOPIC	COLOR TEMP (CCT)	CRI	RATED LIFE (L70)	INPUT VOLTAGE	INPUT FREQUENCY
SL-CLP-TC-40HPLED	40W	4,286	7,072	5000K	70+	>200,000	120~277V	50/60HzCLP-
SL-CLP-TC-50HPLED	50W	5,360	8,844	5000K	70+	>200,000	120~277V	50/60Hz
SL-CLP-TC-60HPLED	60W	6,432	10,613	5000K	70+	>200,000	120~277V	50/60Hz

# Ordering Guide

Example: SL-CLP-TC-50HPLED-50-MV-BZ-3-PC

SL-CLP-TC

MODEL	WATTS	COLOR TEMP	VOLTAGE	FINISH	MOUNTING	OPTIONS
<b>SL-CLP-TC</b>	40W-40HPLED	30-3000K	<b>MV=120-277V</b>	<u>STANDARD:</u>	<b>(3) 3" ROUND POST FITTER</b>	<b>PC-BUTTON PHOTO CELL</b>
	<b>50W-50HPLED</b>	40-4000K		<b>BZ- BRONZE</b>	(4) 4" ROUND POST FITTER	HSS-HOUSE SIDE SHIELD
	60W-60HPLED	<b>50-5000K</b>		<u>ADDITIONAL CHARGE:</u>	(5) 2/8" ROUND POST FITTER	WC-WIRELESS CONTROLS
				GRY-GRAY		MG-MARINE GRADE FINISH
				BLK-BLACK		FAL-FROSTED ACRYLIC LENS
				WH- WHITE		
				CUS-CUSTOM		

## Dimensions

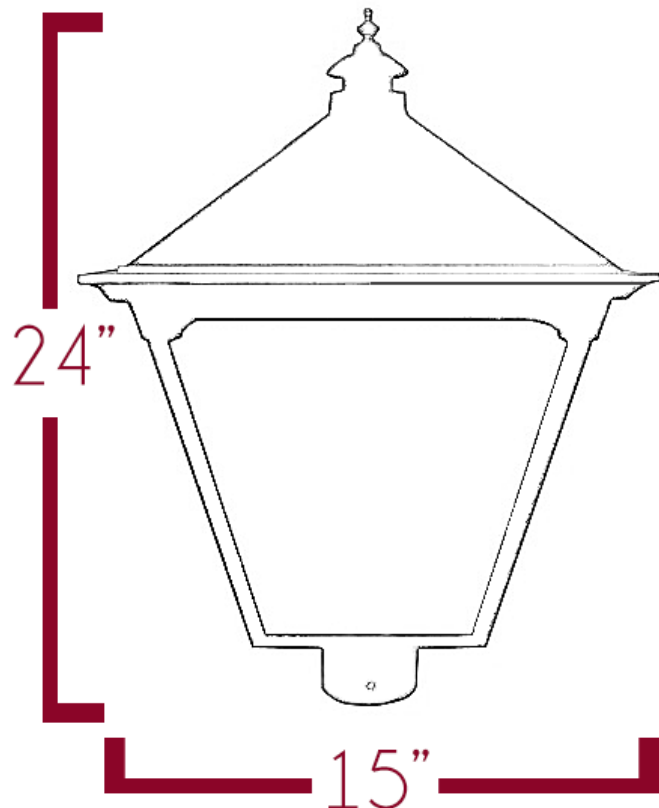

Crystal Lighting Corporation - 13182 Flores St., Santa Fe Springs, Ca. 90670

Phone: 562-944-0223 - Fax: 562-944-0225 - WEB: [www.crystallighting.us](http://www.crystallighting.us)

Crystal Lighting is BUY AMERICAN compliant - All products are proudly manufactured and/or assembled in the USA