



DATE	
PROJECT	
TYPE	
NOTE	
PREPARED BY	

VL-2315

LED Floodlight



The VL-2315 is built with an efficient LED engine that ensures strong luminosity and durability. It is ideal for landscaping and other various locations such as: parking areas, entrances, walkways, underpasses and roadways. The VL-2315 offers competitive pricing and includes a 3 year warranty.

FEATURES

- Starting Temperature: -40°C
- UL & CUL listed for wet locations
- Driver: Constant current, 120V
- Operating life: >50,000 hours
- 3 year warranty



CONSTRUCTION

- Solid construction die-cast aluminum body
- UV stabilized powder coat finish
- Powder coat bronze finish (standard)

OPTIONS

- (SB) Swivel bracket
- (KM) Knuckle mount



SWIVEL BRACKET



KNUCKLE MOUNT

MODEL #	INPUT POWER	LUMEN OUTPUT	SCOTOPIC	COLOR TEMP (CCT)	CRI	RATED LIFE (L70)	INPUT VOLTAGE	INPUT FREQUENCY	HID EQUIVALENT
VL-2315-15LED	15W	1,650	2,723	5000K	70+	>50,000	120V	50/60Hz	70w MH

Ordering Guide

Example: VL-2315-15LED-50-MV-BZ-KM

MODEL	WATTS	COLOR TEMP	VOLTAGE	FINISH	OPTIONS
VL-2315	15W-15LED	50-5000K	MV=120-277V	BZ- BRONZE	(KM) KNUCKLE MOUNT (SB) SWIVEL BRACKET

Dimensions

KNUCKLE MOUNT

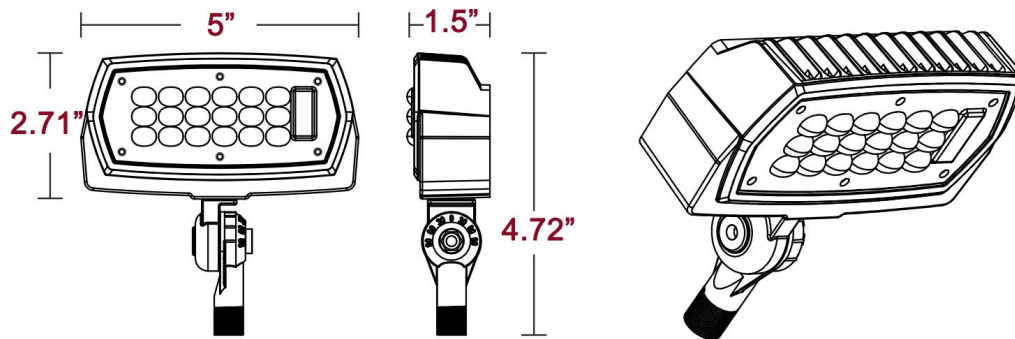

SWIVEL BRACKET

