



DATE	
PROJECT	
TYPE	
NOTE	
PREPARED BY	

**VL-WPDS**

**LED Wall Pack**

The **VL-WPDS** ensures strong luminosity and durability. Available in four different wattages, the **VL-WPDS** is ideal for locations such as: hallways, entrances, underpasses and parking garages. The **VL-WPDS** offers competitive pricing and includes a 3 year warranty.



**FEATURES**

- Starting Temperature: -34.4 ~ 49°C
- UL & CUL listed for wet locations
- Suitable for wet locations
- 5000K
- Driver: Constant current, 100~277V
- Operating life: >100,000 hours
- 3 year warranty



**CONSTRUCTION**

- Solid construction die-cast aluminum body
- Black finish (standard)

MODEL #	INPUT POWER	LUMEN OUTPUT	SCOTOPIC	COLOR TEMP (CCT)	CRI	RATED LIFE (L70)	INPUT VOLTAGE	INPUT FREQUENCY
VL-WPDS-28LED	28W	2,660	4,389	5000K	70+	>100,000	100 ~ 277V	50/60Hz
VL-WPDS-40LED	40W	3,721	6,140	5000K	70+	>100,000	100 ~ 277V	50/60Hz
VL-WPDS-60LED	60W	5,700	9,405	5000K	70+	>100,000	100 ~ 277V	50/60Hz
VL-WPDS-90LED	90W	8,614	14,213	5000K	70+	>100,000	100 ~ 277V	50/60Hz

**DLC Number**

Input Wattage	DLC #
28W	U-IWP-28-50
40W	U-IWP-40-50
60W	U-IWP-60-50
90W	U-IWP-90-50

# Dimensions

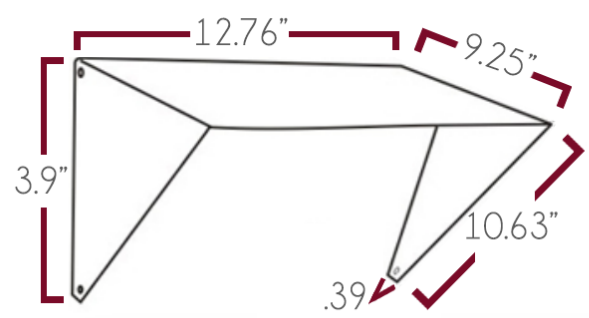
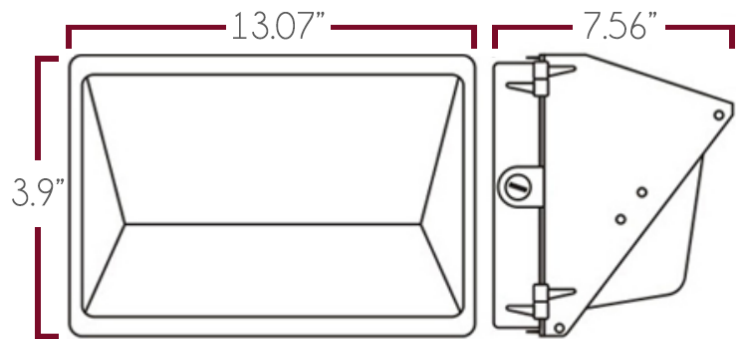

# Ordering Guide

Example: VL-WPDS-28LED-50-100~277V-BZ

## VL-WPDS

MODEL	WATTS	COLOR TEMP	VOLTAGE	FINISH
VL-WPDS	28W-28LED	50-5000K	100~277V	BZ-BRONZE
	40W-40LED			
	60W-60LED			
	90W-90LED			