



DATE	
PROJECT	
TYPE	
NOTE	
PREPARED BY	

CLC-306SM

18" sq. LED garage or gas station light fixture



18" sq. LED garage or gas station light fixture, suitable for wet locations, Perfect for lighting up underpasses, hallways, entry ways, storage areas, parking garages, loading docks, Industrial/commercial spaces. This fixture has a wide light distribution. Comes with a 5 year/50,000 hour limited warranty.

FEATURES

- Energy Savings: Over 66% compared to HID light sources
- Improved lumen maintenance
- Utilizes high efficient Phillips Lumiled LED's
- Operating temperatures: -30°C ~ 60°C
- Driver: Constant current, 120-277v, 50/60Hz, 480v (Optional)
- Suitable for wet locations
- Dimming, occupancy sensors, photo cell capable (optional)
- Operating Life: >60,000 hours

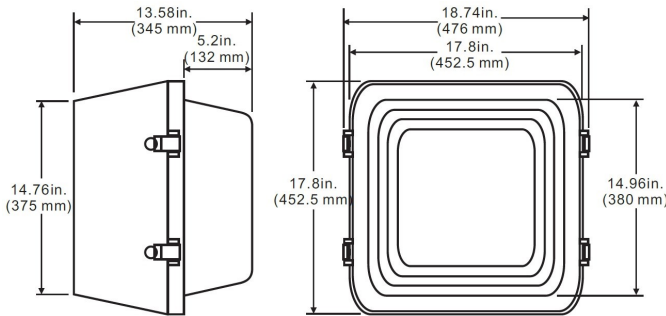

CONSTRUCTION

- Housing is heavy-duty die-cast aluminum backing
- 1/2" Coin plugs with O-rings for conduit, sensors or photo cell
- Powder coat **white finish (standard)** various colors available (custom).
- Clear prismatic glass lens
- Silicone gasket to prevent leakage and provide weather-tight protection.
- Mounting: Cast-in Template for Mounting Directly Over a 4" Recessed Outlet Box or use 1/2" Surface Conduit

OPTIONS

- (OCC) Motion sensor
- (PC) Button photo cell
- (EMR) Emergency battery backup
- (QM) Hinged Quick-Mount Bracket, Stamped Steel, Mount Over Recessed Electrical Box, or Use 3/4" NPS Down-rod for Pendant Mounting



Model Number	INPUT POWER	LUMEN OUTPUT	SCOPTIC	COLOR TEMP (CCT)	CRI	RATED LIFE (L70)	INPUT VOLTAGE	INPUT FREQUENCY	HID Equivalent
CLC-306SM-80CLED	85W	11,008	18,163	5000K	70+	>200,000	120-277V	50/60HZ	250w HPS
CLC-306SM-100CLED	105W	11,926	19,081	5000K	70+	>200,000	120-277V	50/60HZ	400w PSMH
CLC-306SM-120CLED	125W	16,512	26,419	5000K	70+	>200,000	120-277V	50/60HZ	400w HPS

Ordering Guide Example: (CLC-306SM-80CLED-50-MV-WH-PC)

CLC-306SM	MODEL	WATTS	COLOR TEMP	VOLTAGE	FINISH	OPTIONS
CLC-306SM	CLC-306SM	80W-80CLED 100W-100CLED 120W-120CLED	27-2700K 30-3000K 35-3500K 40-4000K 50-5000K 57-5700K 65-6500K	MV=120-277V 480-480V	BZ- BRONZE GRY-GRAY BLK-BLACK WH- WHITE CUS-CUSTOM	OCC- MOTION SENSOR PC- BUTTON PHOTOCCELL EMR- EMR BATTERY QM-QUICK MOUNT

Crystal Lighting Corporation - 13182 Flores St., Santa Fe Springs, Ca. 90670

Phone: 562-944-0223 - Fax: 562-944-0225 - WEB: www.crystallighting.us

Crystal Lighting is BUY AMERICAN compliant - All products are proudly manufactured and/or assembled in the USA