

DATE	
PROJECT	
TYPE	
NOTE	
PREPARED BY	

SM-CLW-303AL

Small Adjustable LED Area/Wall Light

Small adjustable area/wall LED light fixture, suitable for wet locations, Perfect for lighting up residential exteriors, walkways, entry ways, perimeters, parking garages, school campuses, industrial/commercial spaces. This fixture has a wide rectangular light distribution. Comes with a 5 year/50,000 hour limited warranty.

FEATURES

- Energy Savings: Over 66% compared to HID light sources
- Improved lumen maintenance
- Utilizes high efficient Phillips Lumiled LED's
- Operating temperatures: -30°C ~ 60°C
- Driver: Constant current, 120-277v, 50/60Hz, 480v (Optional)
- Suitable for wet locations
- Dimming, occupancy sensors, photo cell capable (optional)
- Operating Life: >60,000 hours

CONSTRUCTION

- Housing is heavy-duty die-cast aluminum
- 1/2" Coin plugs with O-rings for conduit, sensors or photo cell
- Powder coat **bronze finish (standard)** various colors available (custom)
- Clear tempered glass lens
- Silicone gasket to prevent leakage and provide weather-tight protection.
- Mounting: Cast-in Template for Mounting Directly Over a 4" Recessed Outlet Box or use 1/2" Surface Conduit. EZ mount included

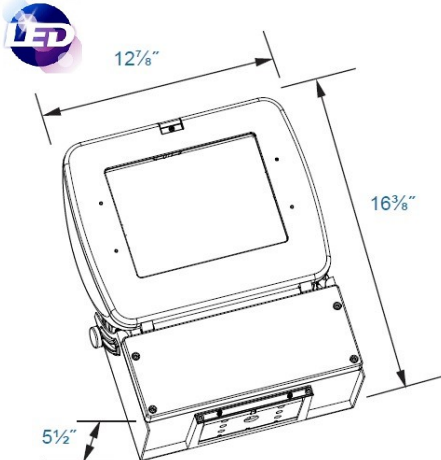

OPTIONS

- (OCC) Motion sensor
- (PC) Button photo cell
- (EMR) Emergency battery backup
- (WC) Wireless Control
- EA6) 6" extruded arm
- (EA10) 10" extruded arm
- (EA12) 12" extruded arm
- (EA18) 18" extruded arm
- (SF) slip fitter



PHILIPS
LUMILEDS

Buy American Compliant

Model Number	INPUT POWER	LUMEN OUTPUT	SCOPTIC	COLOR TEMP (CCT)	CRI	RATED LIFE (L70)	INPUT VOLTAGE	INPUT FREQUENCY	HID Equivalent
SM-CLW-303AL-5CLED	7W	757	1,211	5000K	70+	>200,000	120-277V	50/60HZ	35w HPS
SM-CLW-303AL-10CLED	12W	1,376	2,201	5000K	70+	>200,000	120-277V	50/60HZ	50w HPS
SM-CLW-303AL-15CLED	20W	1,918	3,068	5000K	70+	>200,000	120-277V	50/60HZ	70w HPS
SM-CLW-303AL-21CLED	25W	3,102	4,963	5000K	70+	>200,000	120-277V	50/60HZ	100w HPS
SM-CLW-303AL-40CLED	45W	5,504	8,806	5000K	70+	>200,000	120-277V	50/60HZ	150w HPS

Ordering Guide

Example: (SM-CLW-303AL-40CLED-50-MV-BZ-MS)

MODEL	WATTS	COLOR TEMP	VOLTAGE	FINISH	OPTIONS
SM-CLW-303AL	5W-5CLED 10W-10CLED 15W-15CLED 21W-21CLED 40W-40CLED	27-2700K 30-3000K 35-3500K 40-4000K 50-5000K 57-5700K 65-6500K	MV=120-277V 480-480V	BZ- BRONZE GRY-GRAY BLK-BLACK WH- WHITE CUS-CUSTOM	OCC- MOTION SENSOR PC- BUTTON PHOTOCELL EMR- EMR BATTERY WC- WIRELESS CONTROL EA6- 6" EXTRUDED ARM EA10- 10" EXTRUDED ARM EA12-12" EXTRUDED ARM SF- SLIP FITTER

Crystal Lighting Corporation - 13182 Flores St., Santa Fe Springs, Ca. 90670

Phone: 562-944-0223 - Fax: 562-944-0225 - WEB: www.crystallighting.us

Crystal Lighting is BUY AMERICAN compliant - All products are proudly manufactured and/or assembled in the USA