



| | |
|-------------|--|
| DATE | |
| PROJECT | |
| TYPE | |
| NOTE | |
| PREPARED BY | |

VL-SL27

LED Security Light



The **VL-SL27** has a built-in photocell sensor that is beneficial for enhancing safety and security. It is ideal for locations such as residential exteriors, walkways, perimeters, school campuses, industrial/commercial spaces, and any other pedestrian travelled locations. The **VL-SL27** is also suitable for wet locations. Along with investing in a **VL-SL27** comes a 3 year warranty.

FEATURES

- Energy Savings: Over 66% compared to HID light sources
- Driver: Constant current, 120V, 50/60Hz
- Suitable for wet locations
- Photocell sensor
- Operating life: >50,000 hours

CONSTRUCTION

- Acrylic lens
- Polycarbonate body

| MODEL # | INPUT POWER | LUMEN OUTPUT | SCOTOPIC | COLOR TEMP (CCT) | CRI | RATED LIFE (L70) | INPUT VOLTAGE | INPUT FREQUENCY |
|---------|-------------|--------------|----------|------------------|-----|------------------|---------------|-----------------|
| VL-SL27 | 27W | 2,240 | 3,696 | 4000K | 70+ | >50,000 | 120V | 50/60Hz |

Ordering Guide Example: VL-SL27-12LED-40-120V-BZ

| MODEL | WATTS | COLOR TEMP | VOLTAGE | FINISH |
|---------|-----------|------------|---------|-------------------------|
| VL-SL27 | 27W-27LED | 40-4000K | MV=120V | BZ- BRONZE WH- WHITE |

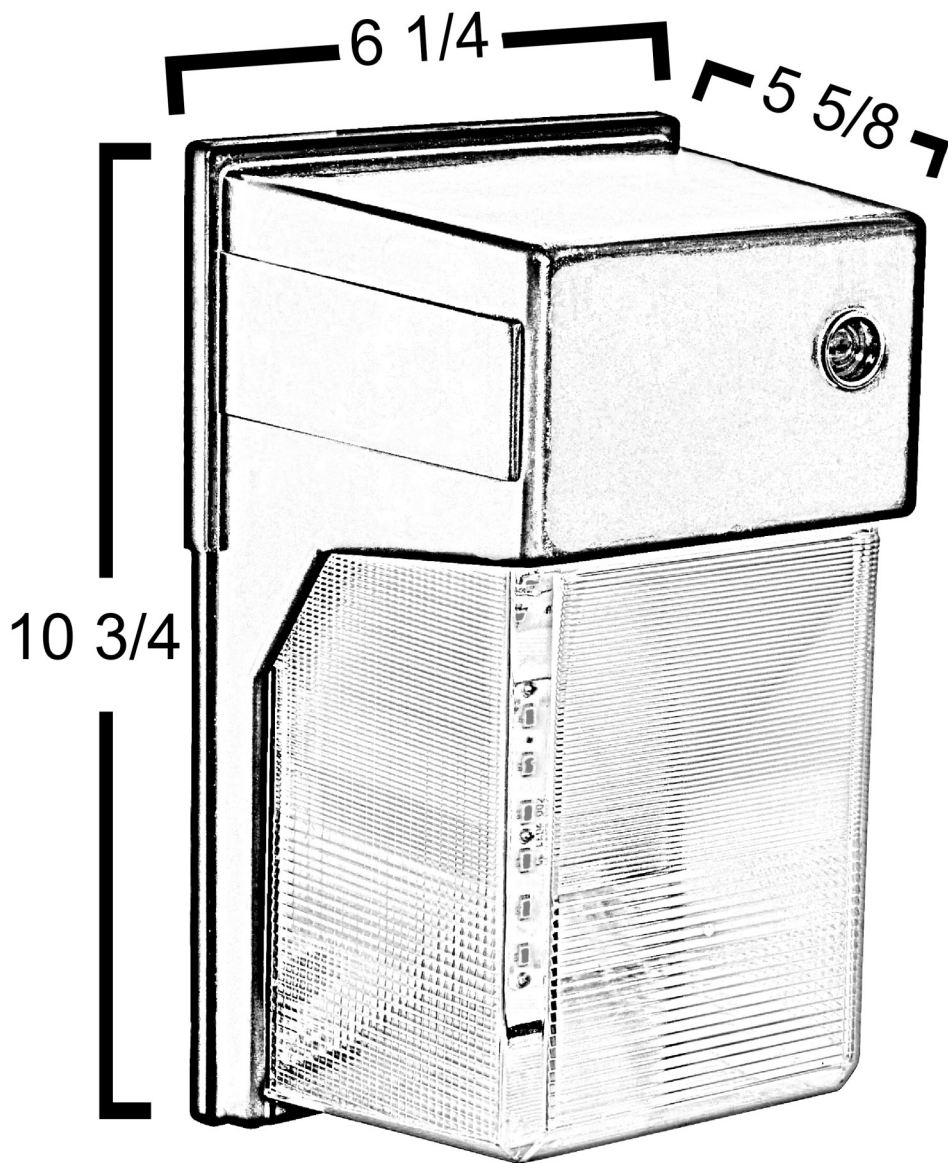

Crystal Lighting Corporation - 13182 Flores St., Santa Fe Springs, Ca. 90670
Phone: 562-944-0223 - Fax: 562-944-0225 - WEB: www.crystallighting.us
Crystal Lighting is BUY AMERICAN compliant - All products are proudly manufactured and/or assembled in the USA