

CL-3099

Wall Pack LED Luminaire
DESIGN-FUNCTION-QUALITY

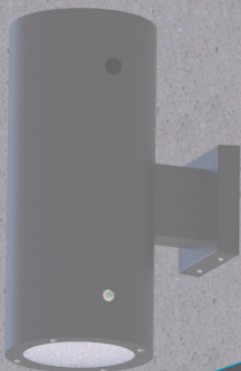

Crystal Lighting Corp.

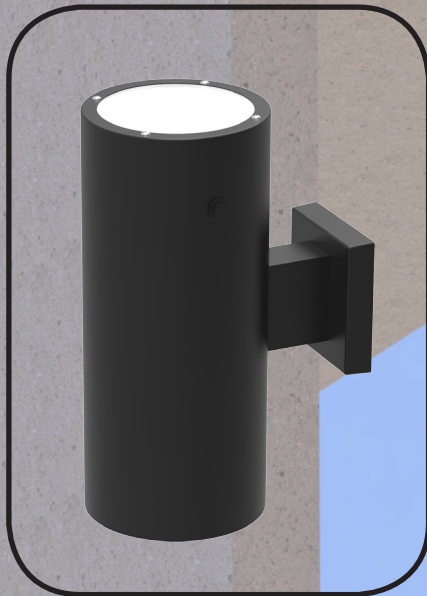
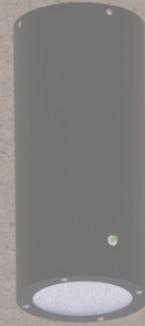

CL-3099 is a sleek, Versatile Cylinder Profile, 3 optional mountings Wall, Ceiling and Pendant Mount. CL-3099 Architectural lighting solution for residential, hospitality and commercial spaces.

• 10 Year/100,000hrs Limited warranty.

FEATURES

- Energy Savings: Over 66% compared to HID light sources
- Improved lumen maintenance
- Utilizes high efficient Phillips Lumiled LED's
- Operating temperatures: -30°C ~ 60°C
- Driver: Constant current, 120-277v, 50/60Hz, 480v (Optional)
- Suitable for wet locations
- 0-10 Dimming Driver, Occupancy Sensors, Photo Cell and Wireless Controls(Optional)
- Optics: 50°, 78° (6" Od and 8" OD)

CONSTRUCTION

- Aluminum Heavy Gauge Housing
- Mounting: Wall Mount, Ceiling or Pendant Options
- Lens options: Type 5 Optic 6" and 8" O.D (Standard) / 4" OD Clear Acrylic Lens (Standard)



Example: CL-3099-8OD-20CLEDD-T2-40K-MV-BRZ-OCC-EMR

CL-3099								
Cat #	Diameter	Light direction	Wattage	Color Temp.	Voltage	Color	Mounting	Options
CL-3099	4" O.D (4OD) -----	Wall Mount Option Up/ Down Light (UDL)	12W (12CLEDD)	3000K (30K) 4000K (40K)	120-277V (MV)	Black (BLK) White (WH) Bronze (BRZ) Silver (SIL) Graphite (GPH) Marine Grade (MG)	Wall Mount (WM)	Emergency Battery (EMR) Button Photo Cell (PC) Wireless controls (WC)
	6" O.D (6OD)	Down Light (DL)	15W (15CLEDD) 20w (20CLEDD)	5000K (50K)			Ceiling Mount (CM)	
	8" O.D (8OD)	Ceiling Mount Down Light (DL)	30W (30CLEDD) 50W (50CLEDD)	*Pendant Mount (PM) <small>*Specify Stem Length</small>				

CL-3099-8" O.D

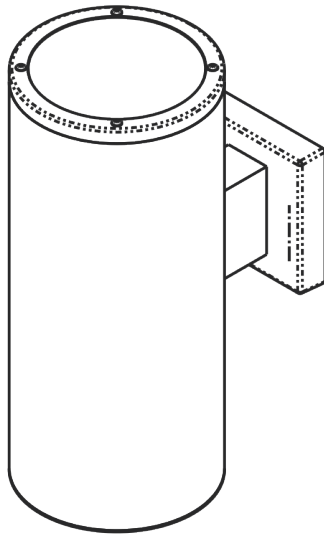

CL-3099-6" O.D

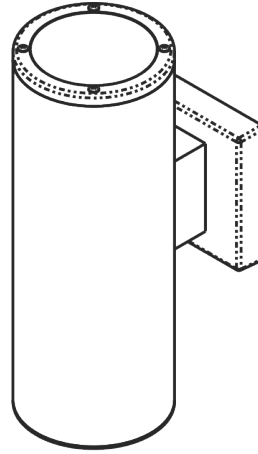

CL-3099-4" O.D

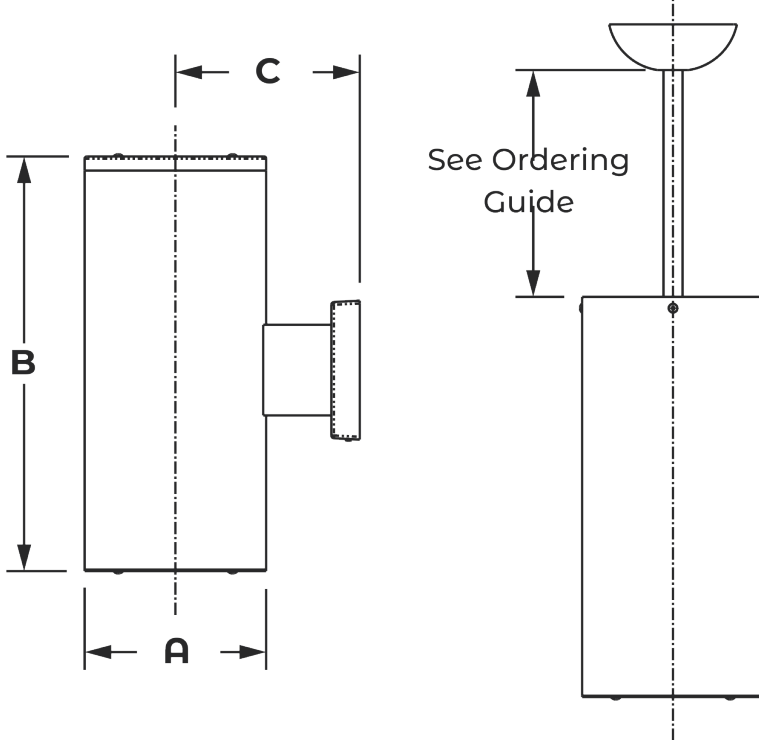
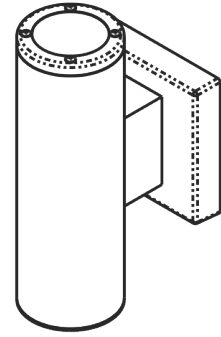

Dimensions			
Cat#	A	B	C
CL-3099-4OD-WM	4" OD	12"	5"
CL-3099-4OD-CM	4" OD	12"	n/A
CL-3099-6OD-WM	6" OD	16"	6" 1/8
CL-3099-6OD-CM	6" OD	16"	n/A
CL-3099-8OD-WM	8" OD	18"	9" 1/4
CL-3099-8OD-CM	8" OD	18"	n/A

Cat #	Input Power	Lumen Output	LPW	Color Temp. (CCT)	CRI	Rated Life (L70)	Input Voltage	HID Equivalent	HID Equivalent
CLP-3099-4OD-12CLED	18W	1,348	112	5000K	70+	>200,000	120-277V	50/60HZ	70W MH
CLP-3099-6OD-15CLED	20W	1,744	116	5000K	70+	>200,000	120-277V	50/60HZ	100W HPS
CLP-3099-6OD-20CLED	25W	2,230	111	5000K	70+	>200,000	120-277V	50/60HZ	100W PSMH
CLP-3099-8OD-35CLED	35W	4,388	125	5000K	70+	>200,000	120-277V	50/60HZ	150W HPS
CLP-3099-8OD-50CLED	55W	6,120	122	5000K	70+	>200,000	120-277V	50/60HZ	175W MH

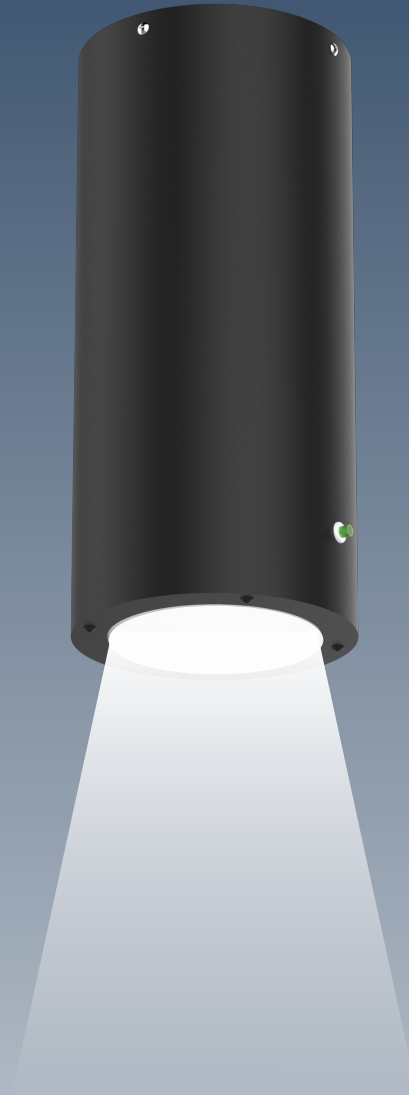

Crystal Lighting
13182 Flores ST.
Santa Fe Springs , CA. 90670
Ph: 562-944-0223
www.crystallighting.us

Proudly manufactured and assembled in the USA