

CLP-BELL

Architectural LED Lighting
DESIGN-FUNCTION-QUALITY



Crystal Lighting Corp.





CLP-BELL Architectural LED Luminaire, suitable for wet locations. Perfect for lighting up Commercial Exteriors, Walkways, Perimeters, School Campuses, Industrial Spaces, Parking Lots, Recreational Parks.

-Dark Sky compliant
-10 Year /100,000 warranty.

Features:

- Energy Savings: Over 66% compared to HID light sources
- Improved lumen maintenance
- Utilizes high efficient Lumiled LED's
- Operating temperatures: -30°C ~ 60°C
- Driver: Constant current, 120-277v or, 480v (Optional)
- 10Kv Surge Protector. (standard)
- 0-10V Dimming, Bottom Photo Cell or wireless controls (optional)

Construction:

- Housing, Heavy Gauge Spun Aluminum.
- Cast Aluminum top for additional support.
- Mounting (YM): Over 3" O.D Tenon or Pole.
- 3 Mill Powder Coat Finish.
- Clear Optic System.

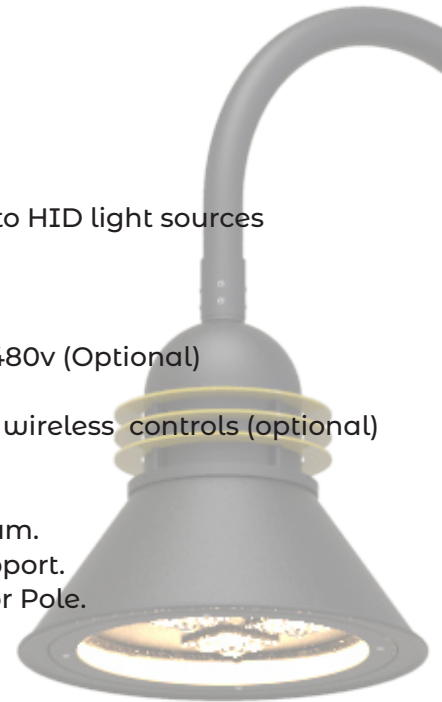

Optic Distribution

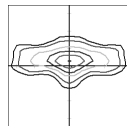

Type 2 (T2)

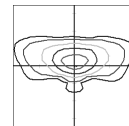

Type 3 (T3)

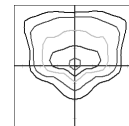

Type 4 (T4)

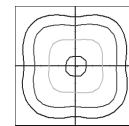

Type 5 (T5)

Example: CLP-BELL-M-TP1-SH1-AM-50CLEd-30K-MV-BRZ-HSS



Cat #	Top/Shade	Mounting	Wattage	Light Dist.	Color Temp.	Voltage	Finish	Options
	Tops	Arm Mount (AM)	40W (40CLEd)	Type 2 (T2)	3000K (30K)	120-277V (MV)	Black (BLK)	Occupancy Sensor (OCC)
CLP-BELL-M (CLP-BELL-M)	Top 1 (TP1)	Yoke Mount (YM)	50W (50CLEd)	Type 3 (T3)	4000K (40K)	480V (HV)	White (WHT)	Button Photo Cell (PC)
	Top 2 (TP2)		60W (60CLEd)	Type 4 (T4)	5000K (50K)		Silver (SLR)	
	(YOKE MOUNT ONLY) Side Slip Arm (SSA) (Over 2" 3/8 Arm)		80W (80CLEd)	Type 5 (T5)			Bronze (BRZ)	
CLP-BELL-LG (CLP-BELL-L) (*UP TO 180W)	Top 3 (TP3)		100W (100CLEd)				Graphite (GPH)	House Side Shield (HSS)
	Shades		120W (120CLEd)				Custom (CST)	Wattage Adjuster (WA)
	Shade 1 (SH1)		150W (150CLEd)					Decorative Rings (DR) (Top 3 Only)
	Shade 2 (SH2)							
	Shade 3 (SH3)		180W (180CLEd)					

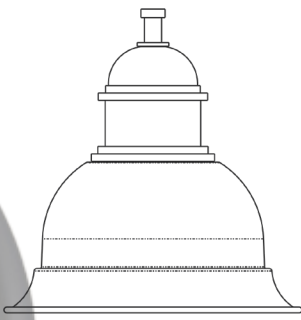

SH1/TP1

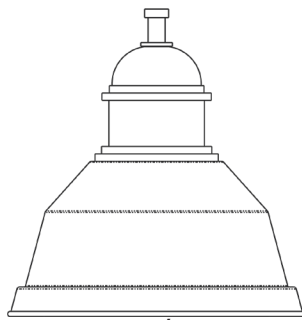

SH2/TP1

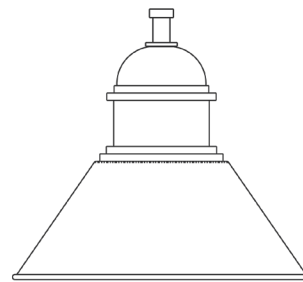

SH3/TP1

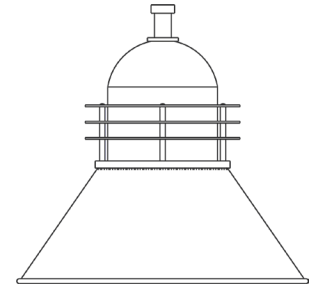

SH3/TP3/DR

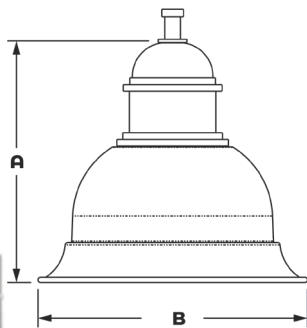

ARM MOUNT
(AM)

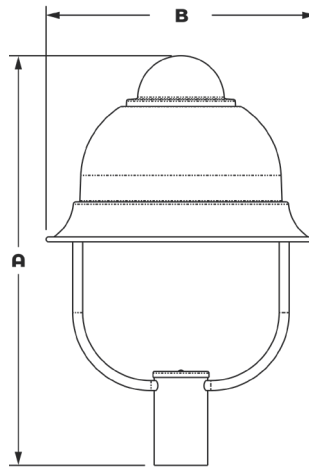

YOKE MOUNT-TOP 2
(YM-TP2)

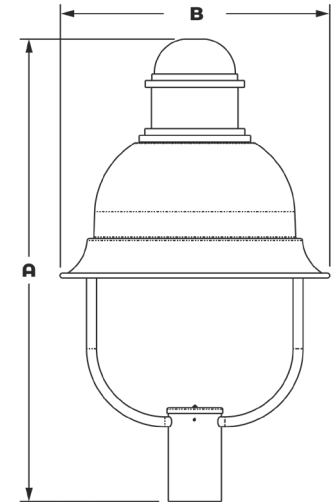

YOKE MOUNT-TOP 1
(YM-TP1)

Cat#	EPA
CLP-BELL-m-AM	1.38
CLP-BELL-m-PT1-ym	1.83
CLP-BELL-m-PT2-ym	1.59
CLP-BELL-L-AM	1.67
CLP-BELL-L-PT1-ym	2.14
CLP-BELL-L-PT2-ym	1.90

Cat#	A	B
CLP-BELL-m-AM	18"	20"
CLP-BELL-m-PT1-ym	37" 3/8	20"
CLP-BELL-m-PT2-ym	31" 7/8	20"
CLP-BELL-L-AM	20"	25"
CLP-BELL-L-PT1-ym	38" 7/8	25"
CLP-BELL-L-PT2-ym	33" 3/8	25"

Cat #	Input Power	Lumen Output	LPW	Color Temp. (CCT)	CRI	Rated Life (L70)	Input Voltage	HID Equivalent
CLP-BELL-m-40CLED	45W	5,504	122	5000K	70+	>200,000	120-277V	70W HPS
CLP-BELL-m-50CLED	55W	6,880	125	5000K	70+	>200,000	120-277V	100W MH
CLP-BELL-m-60CLED	65W	8,256	127	5000K	70+	>200,000	120-277V	150W PSMH
CLP-BELL-m-80CLED	85W	9,590	119	5000K	70+	>200,000	120-277V	175W MH
CLP-BELL-m-100CLED	105W	12,306	123	5000K	70+	>200,000	120-277V	250W PSWH
CLP-BELL-m/L-120CLED	125W	16,012	133	5000K	70+	>200,000	120-277V	310W HPS
CLP-BELL-m/L-150CLED	155W	19,098	127	5000K	70+	>200,000	120-277V	400W PSMH
CLP-BELL-L-175CLED	180W	23,429	130	5000K	70+	>200,000	120-277V	500W PSWH

Proudly Manufactured and Assembled in the USA



Crystal Lighting
13182 Flores ST.
Santa Fe Springs , CA. 90670
Ph: 562-944-0223
www.crystallighting.us

Proudly manufactured and assembled in the USA