

Marine is designed with quality aluminum die-cast material which enables long durability. The Marine is commonly installed in outdoor locations such as: residential areas, shopping districts, and public buildings.
 - 10 year/100,000 hour limited warranty.

Features

- Energy Savings: Over 66% compared to HID light sources
- Improved lumen maintenance
- Utilizes high efficient Phillips Lumiled LED's
- Operating temperatures: -30°C ~ 60°C
- Driver: Constant current, 120-277v, 50/60Hz, 480v (Optional)
- Suitable for Wet Locations
- Dimming, Photo Cell Capable (optional)
- Operating Life: >60,000 hours

Construction

- Cast Aluminum Housing
- Frosted White Glass
- 3 Mills Powder Coating, Bronze Finish
- Silicone gasket to prevent leakage and provide weather-tight protection.



Example: MRN1-10W-30K-MV-BLK-WM



Cat #	Wattage	Color Temp.	Voltage	Finish	Mounting	Options
Marine 1 (MRN1) Round Shape	10W (10CLED)	3000K (30K) 4000K (40K)	120-277V (MV)	Black (BLK) White (WHT) Silver (SLR) Bronze (BRZ) Graphite (GPH) Custom (CST)	Wall Mount (WM)	Bottom PhotoCell (PC)
Marine 2 (MRN2) Oval Shape	20W (20CLED)	5000K (50K)				



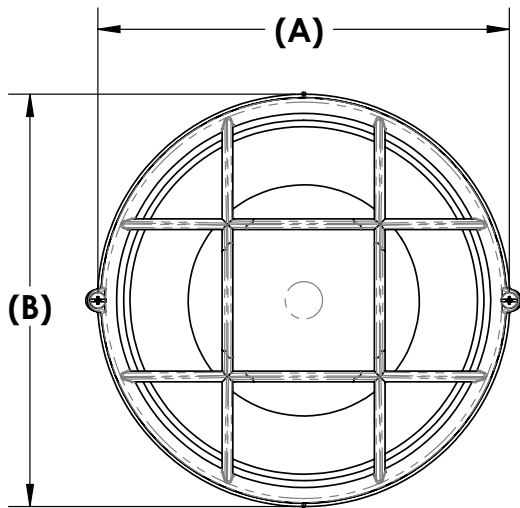

CAT#	A	B	C
MRN-1	9" 5/8	9" 5/8	6"
MRN-2	11"	6" 1/4	6"

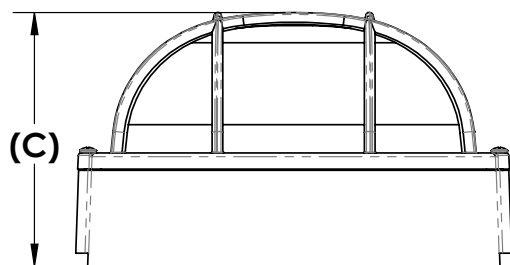

Cat #	Input Power	Lumen Output	LPW	Color Temp. (CCT)	CRI	Rated Life (L70)	Input Voltage	HID Equivalent
MRN - 1/2-10CLED	15W	3,680	184	5000K	70+	>200,000	120-277V	100W MH
MRN - 1/2-20CLED	25W	6,492	162	5000K	70+	>200,000	120-277V	150W MH



Proudly Manufactured and Assembled in the USA