

DA21 is Constructed of Extruded Aluminum Tubing. Arm mount over Round Poles or Tenons of 3", 3-1/2", 4", 4-1/2", or 5" OD, and is Secured with (6x) 3/8" Stainless Steel Set Screws. Contact us for custom configuration or others mounting. All Decorative Arms are Proudly Designed, Fabricated and Assembled in the USA.

DA21-SGL

DA21-D180

DA21-WM

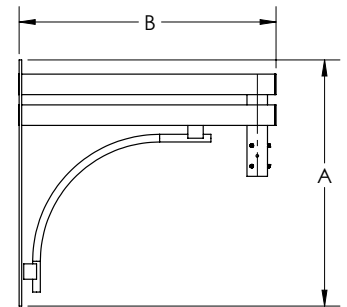
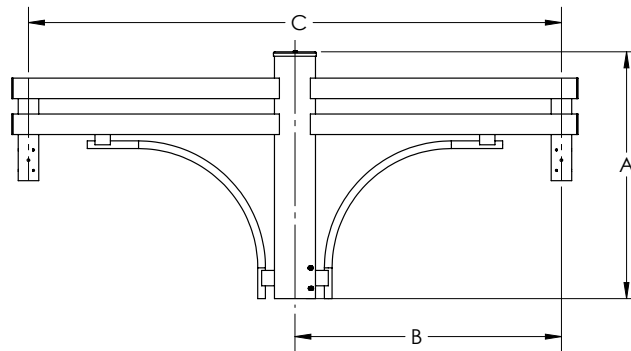
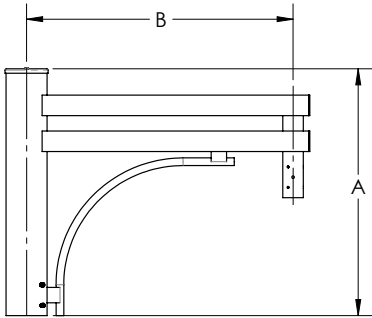

Cat#	Dimensions			EPA
	A	B	C	EPA
DA21-SGL	24"	26"	-	1.62
DA21-D180	24"	26"	52"	3.81
DA21-WM	24"	25"	-	.91

Example: (DA21-SGL-3-BLK)

DA21			
Cat #	Mounting	Diameter (Pole or Tenon)	Color
Decorative Arm 21 (DA21)	Single (SGL)	3" OD (3)	Black (BLK)
	Double 180° (D180)	3 1/2" OD (312)	White (WH)
	Wall Mount (WM)	4" OD (4)	Bronze (BRZ)
		4 1/2" OD (412)	Silver (SIL)
		5" OD (5)	Graphite (GPH)
			Custom (CST)